



Automatic Dry Prime 250 series



DRY PRIME PUMPS

Part number 150x125-250A-ADP50

Page 1 of 2

version 4

APPLICATIONS:

The Poseidon range of heavy duty end suction Automatic Dry Priming Centrifugal pumps have been designed for use in commercial, industrial and mining dewatering applications. Fitted as standard with the SMARTPRIME™ 50cfm diaphragm priming pump for fast and efficient priming up to 8.4m suction head. For applications with a lot of pumped air, the priming system can be upgraded with the 100cfm unit. These pumps are ideal for pressurisation, transfer of fluids, water supply, irrigation, dewatering and for all those applications that need high head and flow rates or for high air removal requirements such as spear/ wellpoint dewatering.

PUMP CONSTRUCTION:

Make:	Poseidon
Model:	150x125-250-A
Pump type:	Centrifugal
Impeller type:	Closed vane impeller, maximum solid size 29 mm
Impeller diameter:	278 mm
Inlet size:	150 mm
Outlet size:	125 mm
Material types:	Standard construction
Casing:	Ductile iron***
Impeller:	Cast iron***
Shaft:	431 stainless steel***
Wear rings:	Standard with cast iron wear rings
Mechanical seal:	Sic / Sic / Viton cartridge seals
Bearings:	Heavy duty taper roller and ball bearings in oil bath
Total dry weight:	469 kg
Flange standard	For water fittings ANSI standard class 150 For engine bellhousing SAE 3 standard

Alternatives:*** Alternative metalurgies available including Bronze, 304, 316 and Duplex Stainless Steels

PUMP DUTY: with SMARTPRIME™

Head - maximum:	78 m
Flow - maximum:	518 m ³ /hour or 144 L/sec
Shaft power - maximum:	88 kw
Speed - maximum:	2600 rpm
Maximum ambient temperature:	60° C
Maximum fluid temperature:	80° C
Maximum casing pressure:	16 bar
Maximum test pressure:	36 bar
Performance curves:	The performance curves are based on a kinetic viscosity value of 1mm ² /s and a density of 1000kg/m ³ at 15°C

SMARTPRIME™ Complete with the patented SMARTPRIME™ diaphragm pump and priming chamber
 As standard the pump is fitted with a 50cfm diaphragm pump, larger 100cfm systems also available
 The priming chamber is fitted with the fail proof SMARTPRIME™ stainless steel safety valve and floats that make the Poseidon pump one of the most environmentally friendly pumps available in the market

MECHANICAL DIMENSIONS FOR 150x125- 250 SERIES

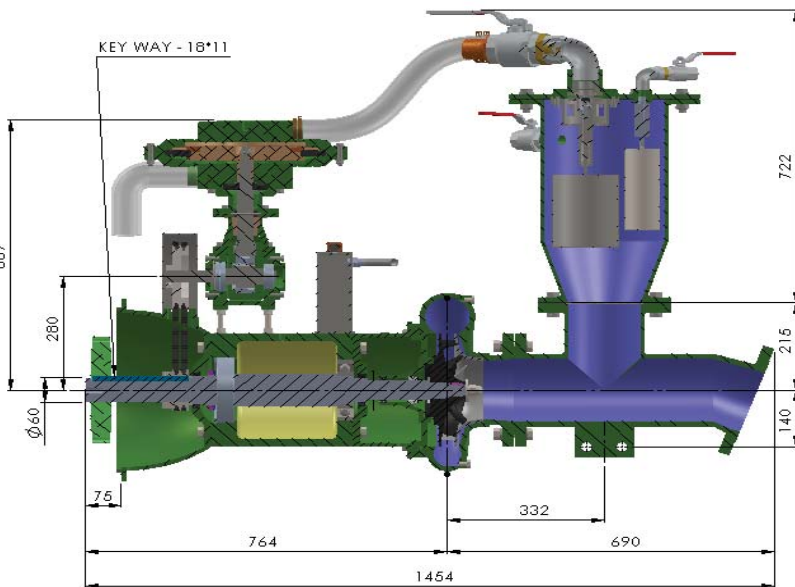
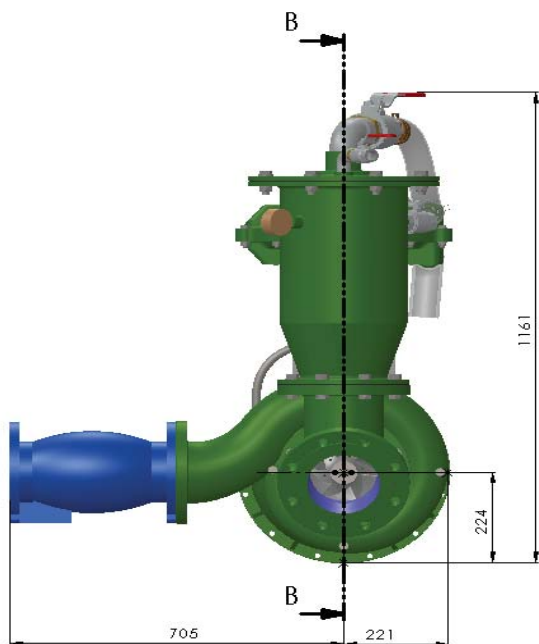

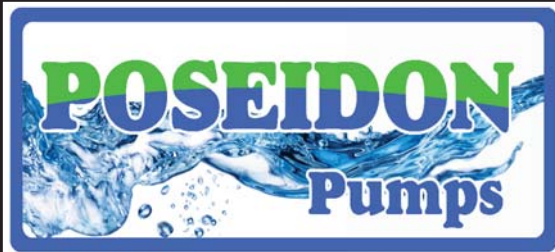

Automatic Dry Prime 250 series



DRY PRIME PUMPS

Part number 150x125-250A-ADP50

Page 2 of 2

version 4

Variable speed - faster speeds:

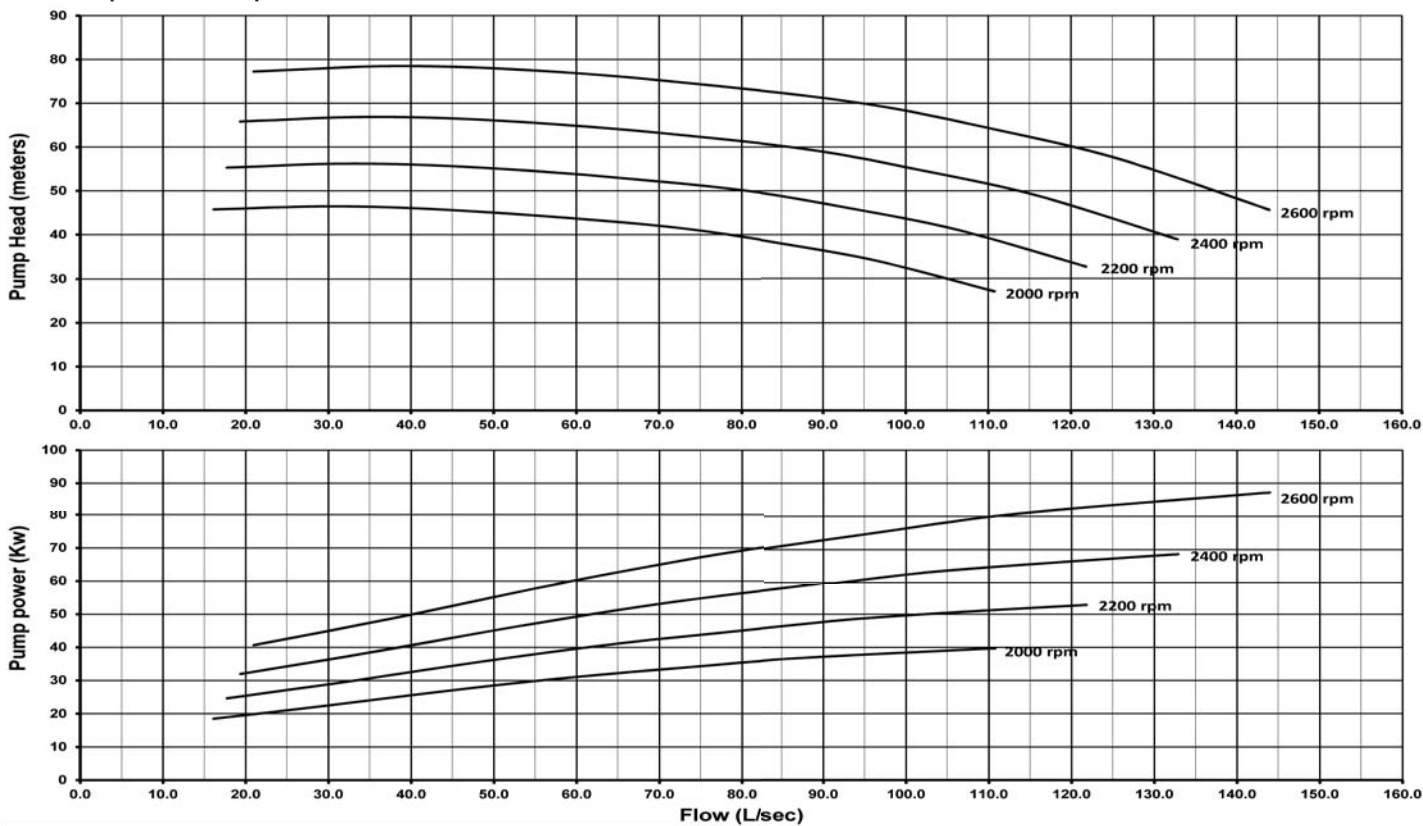

Variable speed - slower speeds:

